







Part Number: H451SAL100

Description: Fog Light Kit, Outback

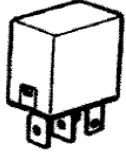
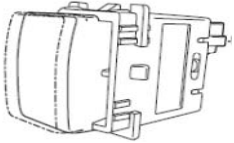
Kit Contents

<p>A</p>  <p>Fog Light, Driver: 1</p>	<p>B</p>  <p>Fog Light, Passenger: 1</p>	<p>C</p>  <p>Relay: 1</p>	<p>D</p>  <p>Switch: 1</p>
<p>C</p>  <p>Nut: 4</p>	<p>D</p>  <p>Clip: 4</p>	<p>E</p>	<p>F</p>

Tools Required

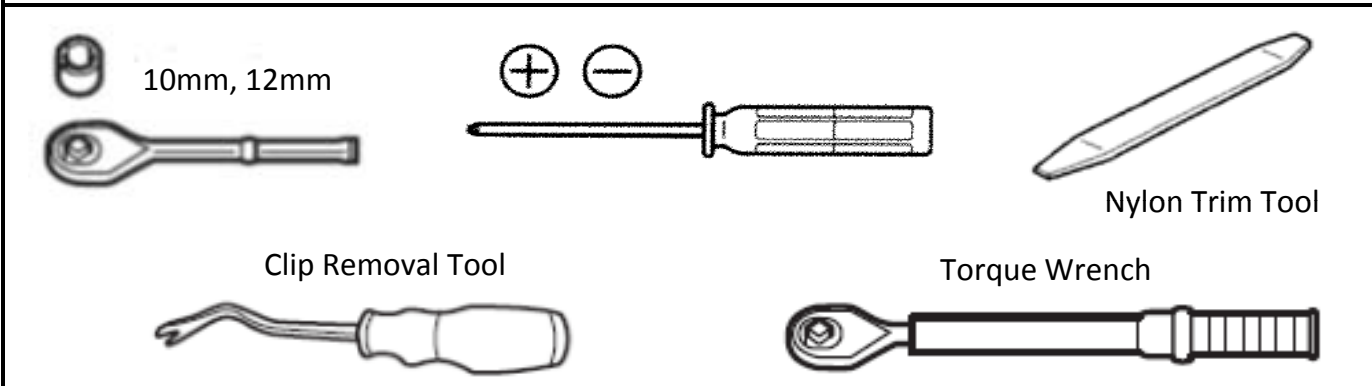

Icon Legends / Cautions



: Remove/Disconnect



: Install



: Location of clip or screw

- 1) Read all instructions before proceeding with installation. If uncomfortable performing any procedures, such as lamp aiming in final step, have installation performed by a Subaru dealer technician.
- 2) Take care not to damage vehicle components during removal and installation.
- 3) Route wiring so that it does not rub against any sharp edges.

Part Number H451SAL100	Issue 1	Date 6/10/2014	SUBARU OF AMERICA	Page 1/6
---------------------------	------------	-------------------	-------------------	-------------

Installation

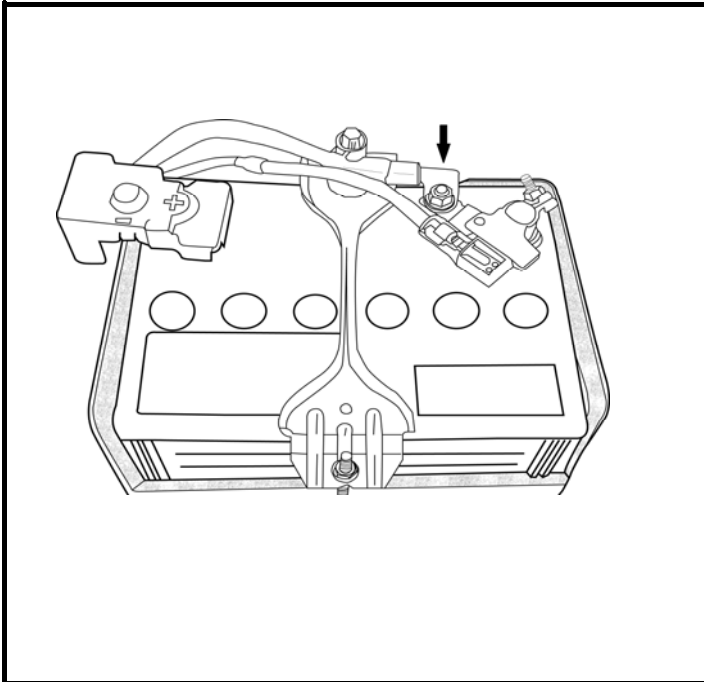

1

2

Disconnect negative battery terminal using 12mm socket wrench.

Remove the clips and turn over the front right mud guard. Remove 5 clips from fender liner where shown and pull down. Free fog lamp harness connector from the breakaway tape.

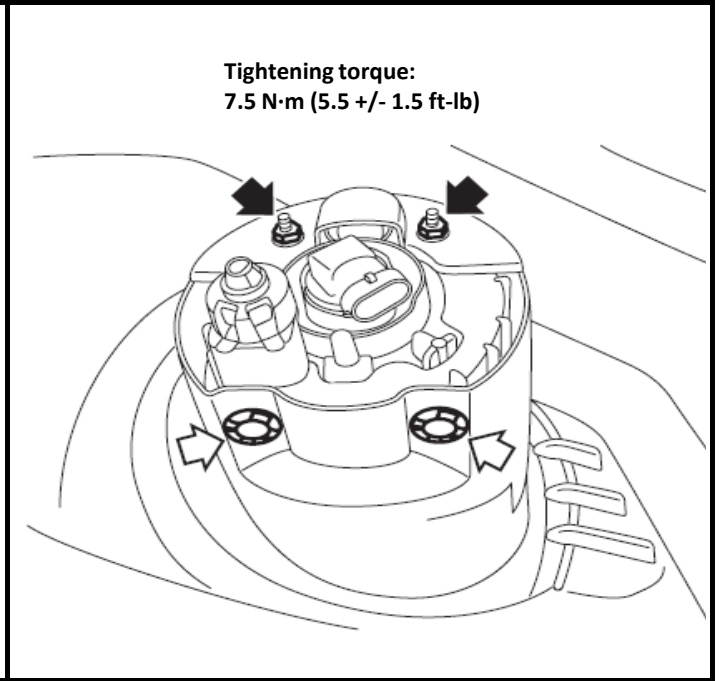
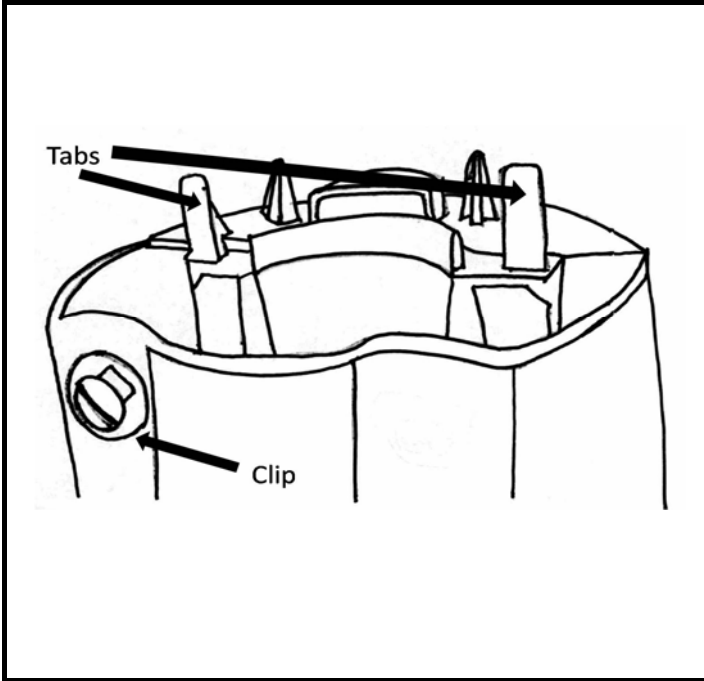

3

4

Remove clip and press tabs to remove cover plate. Properly discard cover plate.

Insert lamp assembly (A) into bumper cavity. Install nuts (E) and clips (F). Tighten nuts securely to the torque specified above.



Part Number: H451SAL100

Description: Fog Light Kit, Outback

Installation

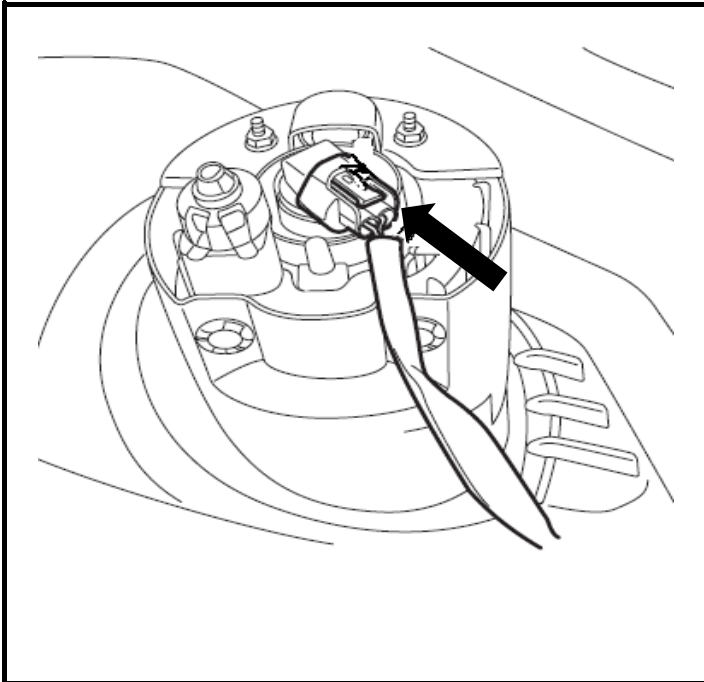

5

Connect the fog lamp connector to the fog lamp assembly. Ensure that the tab locks into place.

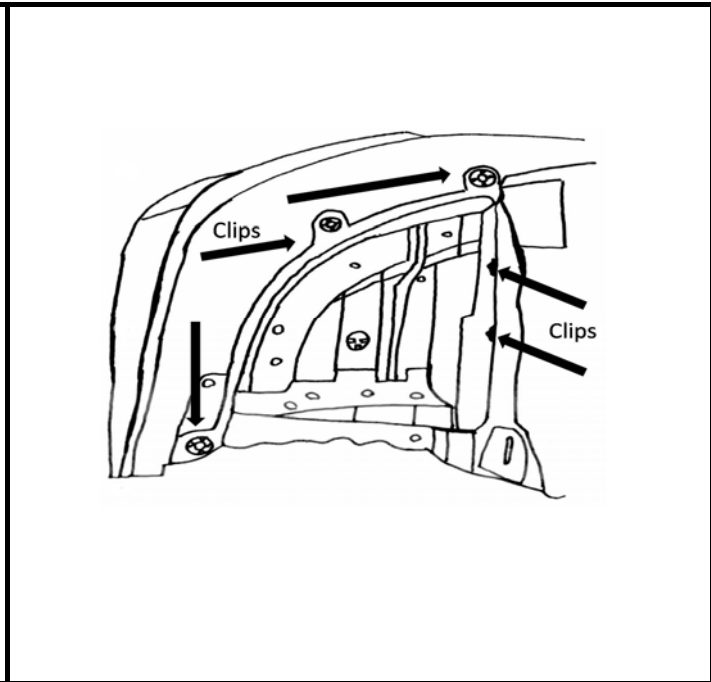

6

Install fender liner and 5 clips removed in step 2.

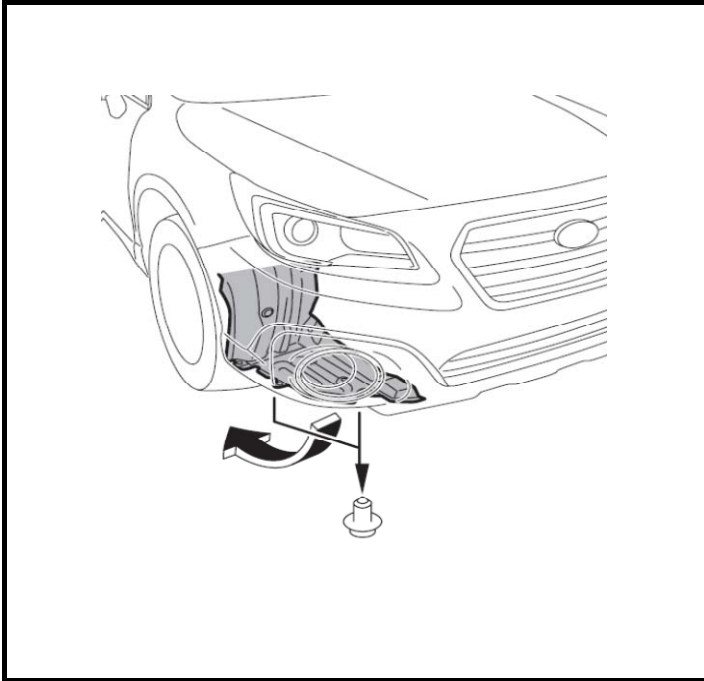

7

Repeat steps 2-6 for passenger side.

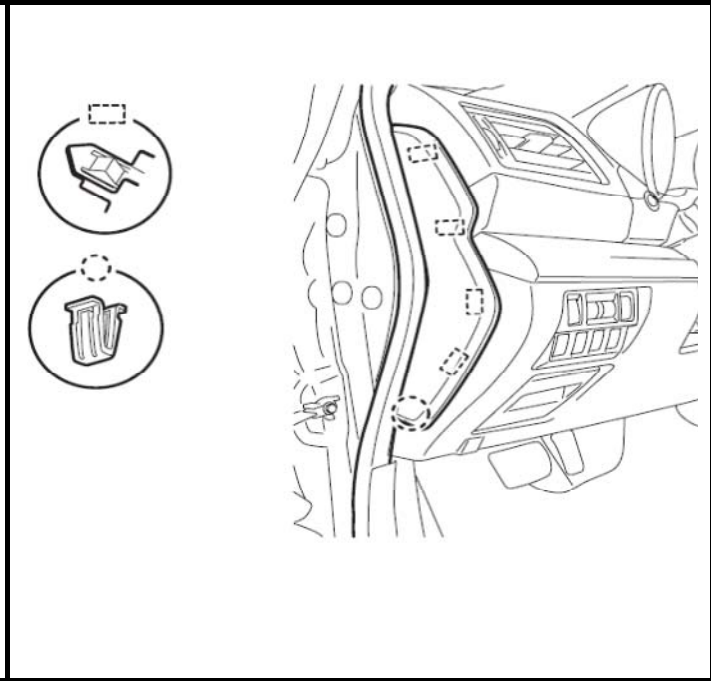

8

Remove the clips, and remove the cover - instrument panel side LH.

Installation

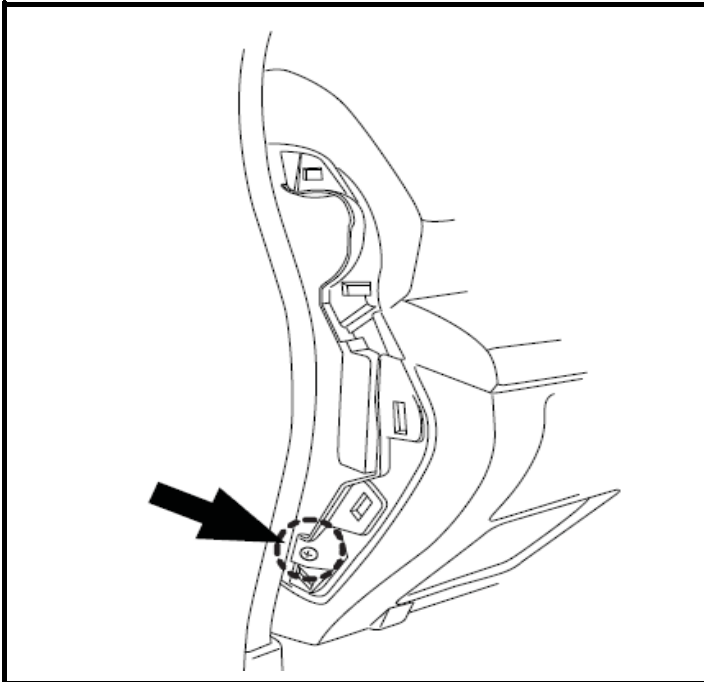

9

Remove the Philips screw as shown.

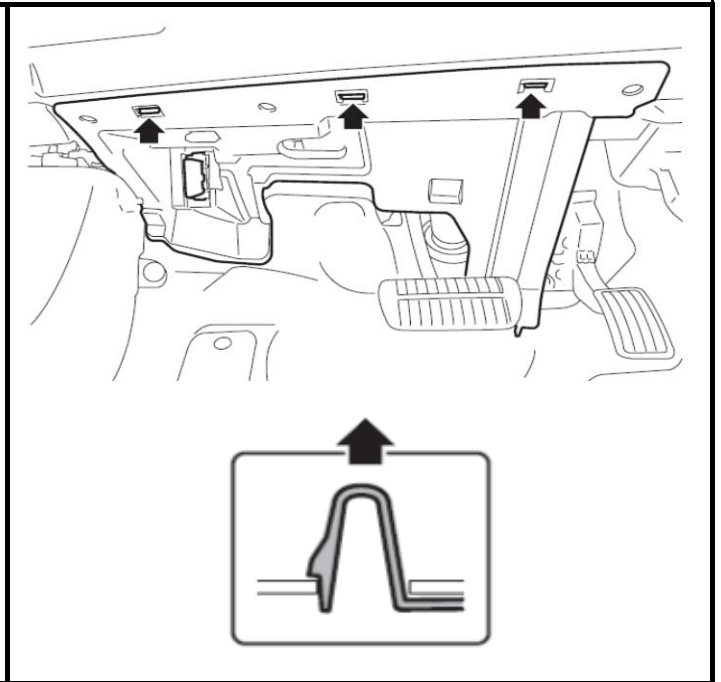

10

Remove the data link connector and release the hook, and then remove the under cover assembly - driver.

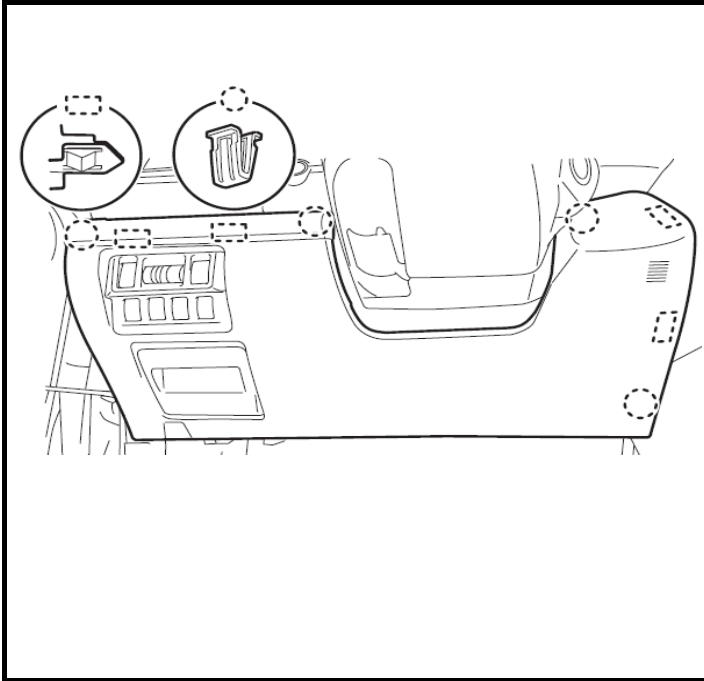

11

Release the clips and claws of the instrument panel LWR driver.

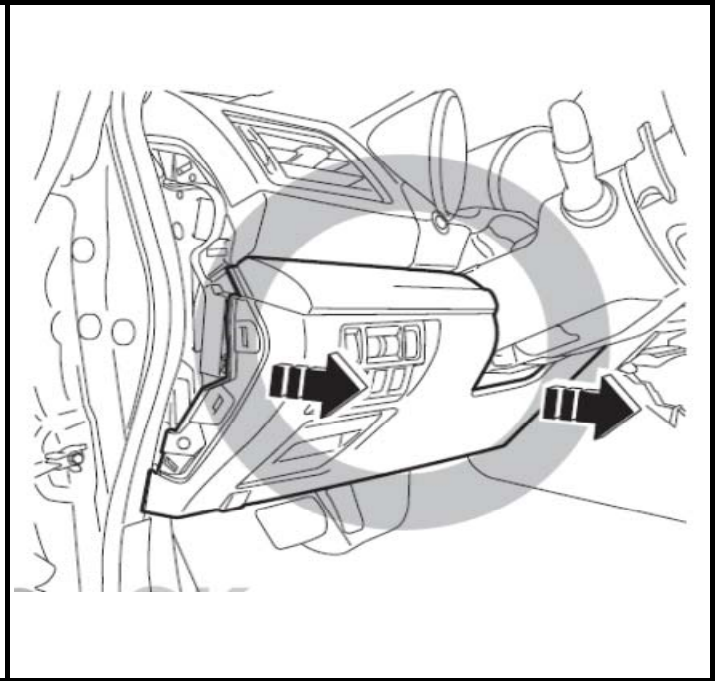

12

Pull the instrument panel LWR driver toward the driver seat to disengage from the lower dash.

Installation

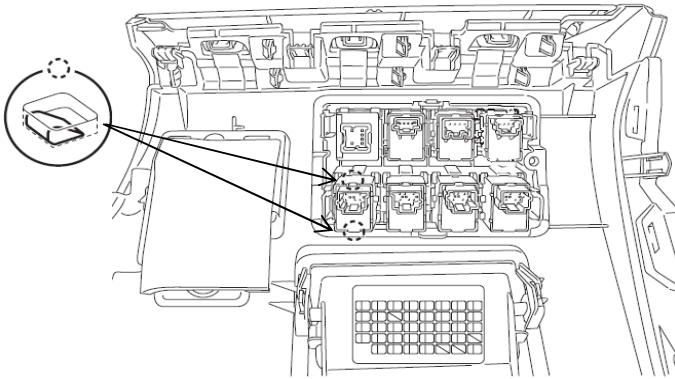

(Rear of lower instrument panel shown)

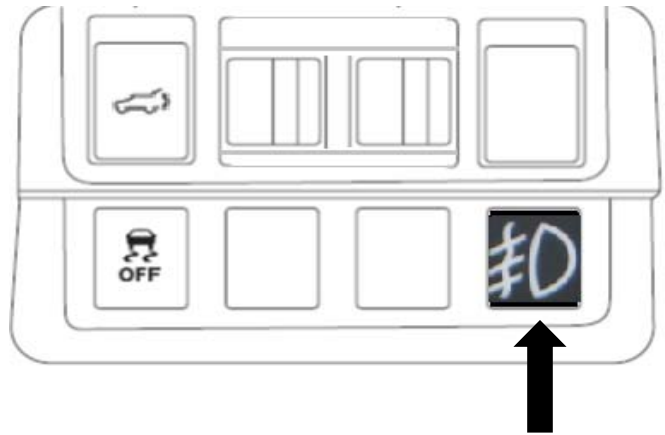

13

Disengage the pre-arranged fog lamp switch connector from the switch blank. Release the claws and remove the switch blank at the bottom right of the switch panel.

14

Insert the fog lamp switch (E) into the switch panel. Make sure the switch is inserted in the correct orientation in the bottom right opening on the switch panel and is locked in place. Wrap the supplied foam tape around the connectors to prevent rattles.

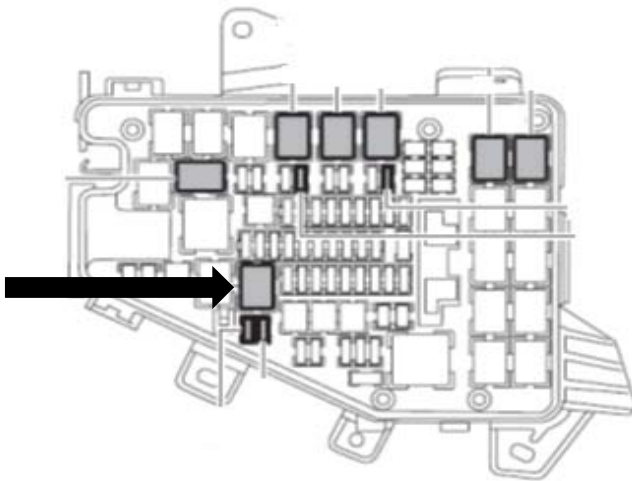

15

Open main fuse box in engine bay. Insert relay (C) in position shown by arrow. Replace fuse box cover.

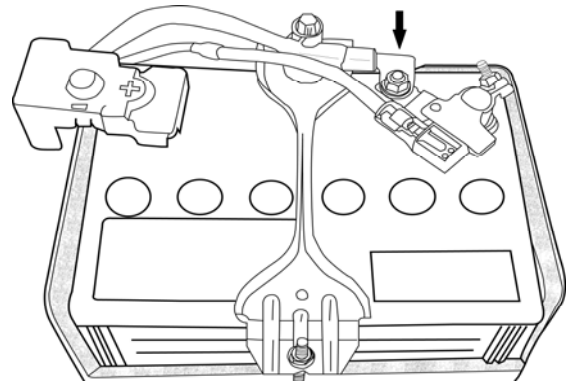

16

Reconnect negative terminal to battery. Tighten with 12mm socket wrench.

Fog Lamp Aiming Procedure

- 1) Before checking fog light beam level, confirm the following:
 - Body area around fog light has not sustained any damage or other type of deformation.
 - Vehicle is parked on a level surface.
 - Inflation pressure of tires is correct.
 - Vehicle fuel tank is fully filled.
- 2) Bounce vehicle several times to normalize suspension.
- 3) Make certain someone is seated in the driver's seat.
- 4) Park vehicle with front end facing wall.

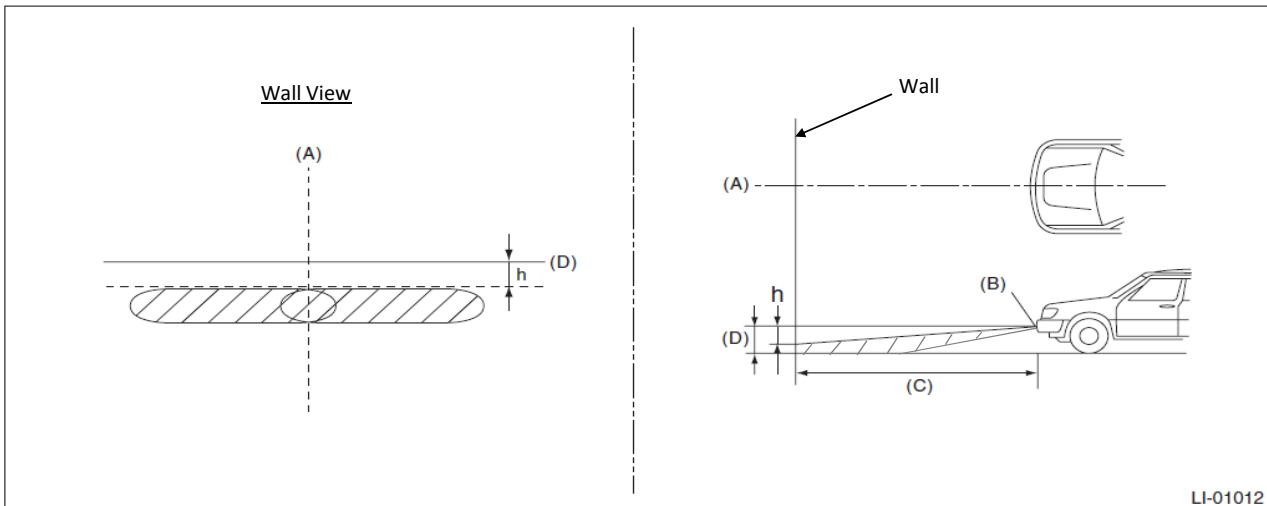

LI-01012

(A) Vehicle center

(C) 3 m (10 ft)

(D) Height of fog light center

(B) Bulb center marking

h mm (in) at 3 m (10 ft)
40 (1.58)